

71ST ANNUAL CONFERENCE & EXPO EXHIBITOR PROSPECTUS

MAY 19 - 20, 2020

TURNING STONE RESORT & CASINO | VERONA | NEW YORK

TARGET AUDIENCE

- Owners / Operators
- Administrators
- Executive Directors
- Medical Directors
- DONs
- Members of the Clinical Team for SNFs
- Staff of Assisted Living Facilities



EXHIBIT INFORMATION

NYSHFA / NYSCAL EXPO HELD IN CONJUNCTION
WITH OUR ANNUAL CONFERENCE

DATE & TIME:

Tuesday, May 19, 2020
3:00pm - 5:00pm

Wednesday, May 20, 2020
11:45am - 1:45pm

WHERE:

Turning Stone Resort & Casino • 5218 Patrick Road • Verona • New York 13478

EXHIBIT FEES

SINGLE SPACE RENTAL: Associate Members: \$975.00 | Non-Members: \$1,275.00

DOUBLE SPACE RENTAL: Associate Members: \$1,950.00 | Non-Members: \$2,550.00

DESCRIPTION OF STANDARD EXHIBITION SPACES

All spaces will consist of a 10'W x 10'D x 8'H back wall and (2) two 3'H side rails

Each space will receive the following:

1. One 6' draped table (6 L x 24"W x 30"H)
2. A table covering consisting of white flame proof vinyl
3. A table skirt with flame proof fabric covering the 6' side and the (2) two 24" sides
4. Two side chairs and a waste basket
5. One 7" x 44" space identification sign with 2" computer cut vinyl letters

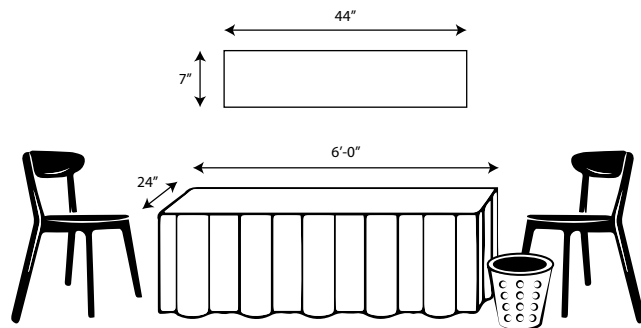

ANNUAL CONFERENCE APP

Exhibitors will have their company logo and contact information listed on the app.
Please email your high resolution logo to **Erin Fitzgerald** at efitzgerald@nyshfa.org by April 17, 2020.

HOTEL ACCOMMODATIONS

An exhibitor room block has been established at the Turning Stone Resort & Casino.
In order to receive the NYSHFA / NYSCAL discount you must use the reservation code.

EXHIBITOR CONTRACT

PART I

ATTENTION EXHIBITORS! The information you provide will appear on our Conference App

Are you an Associate Member of NYSHFA / NYSCAL: YES NO

Company / Organization Name: _____

Contact Person: _____

Address: _____

City: _____ State: _____ Zip Code: _____

Phone: (_____) _____ Fax: (_____) _____

E-mail: _____ Website: _____

Brief Company Description* _____

*This information will not be used for the Conference App

Company Logo: Please email your hi-rez vector EPS or PNG logo to Erin Fitzgerald at efitzgerald@nyshfa.org for the Annual Conference App.

EXHIBIT REGULATIONS

- 1. INSTALLATION OF EXHIBITS:** Exhibitors may commence installation of exhibits at 10:00am on Tuesday, May 19, 2020, and must complete such installation no later than 2:00pm on Tuesday, May 19, 2020, as the Expo hall opens at 3:00pm.
- 2. INAPPROPRIATE EXHIBITS:** NYSHFA / NYSCAL reserve the right to control or prohibit any exhibit deemed by NYSHFA / NYSCAL, in its sole discretion, to be inappropriate. Aisle space may NOT be used for exhibit purposes, displays of signs, solicitations or distribution of cards, circulars, samples, or other promotional materials.
- 3. PROHIBITIONS:** Exhibits, signs, or displays are prohibited in any public rooms or elsewhere on the premises of the exhibit hall or Headquarters Hotel.
- 4. AUDIO/VISUAL DEVICES:** The use of amplification devices (megaphones, loudspeakers) or undignified methods of attracting attention are prohibited. The use of filming, taping (video) or audio recording equipment will be permitted only if prior written permission from NYSHFA / NYSCAL is obtained.
- 5. PRINTED MATERIALS:** Distribution of printed or promotional materials may be done only in the assigned exhibition space. Distribution of materials in all other places without written permission is prohibited.
- 6. PERSONNEL AT EXHIBITION SPACE:** At least one representative of the Exhibitor, who is pre-registered for the Expo, must be in attendance at the exhibition space at all times when the exhibit area is open.
- 7. EXHIBIT HALL:** Only exhibitors and persons registered for the Expo will be allowed in the exhibit hall. Anyone excluded by this policy, who wishes to visit the exhibit hall, may purchase a ticket at registration.
- 8. IDENTIFICATION BADGES:** Admission to the exhibit hall will be by identification badge only. Only NYSHFA / NYSCAL-supplied name badges may be used on the exhibit hall floor. Other badges, name tags, or items that identify a firm / company by name, may not be displayed.
- 9. SHIPMENTS:** Turning Stone Resort will not accept exhibition shipments. Please contact Clifton Park Rental Center at (518) 877-7449 for a drayage form.
- 10. AMENDMENTS TO RULES AND REGULATIONS:** All matters and questions not covered by the Contract or these rules and regulations are subject to the decision of NYSHFA / NYSCAL. NYSHFA / NYSCAL have sole authority to promulgate, interpret and enforce these rules and regulations and to make any amendments to the regulations as necessary for the orderly conduct of the Expo and the exhibit hall.
- 11. DECORATOR OF EXHIBITS:** The official decorator of the 2020 Expo is Clifton Park Rental Center. Request forms for exhibition space decorating will be emailed to Exhibitors from Clifton Park Rental Center approximately five weeks before the Expo. Requests for information concerning special equipment, electricity, carpeting, labor and drayage should be directed to: Ms. Tracy Cline, Clifton Park Rental Center, 871 Main Street, Clifton Park, NY 12065; Phone (518) 877-7449; Email tccline@cliftonparkrental.com.
- 12. FOOD & BEVERAGE:** No outside food or beverage is permitted to be brought into the Exhibit Hall.

EXHIBITOR CONTRACT

PART II

If you wish to reserve your space, please return your company information and signed contract along with payment. Spaces are sold on a first come, first serve basis.

- 1. GENERAL:** This contract and the attached rules and regulations (collectively the "Contract") contain the terms and conditions upon which the company whose name is printed above the heading Company Name at the end hereof (the "Exhibitor") shall have the right and privilege to reserve space and conduct an exhibition space in the exhibit hall at the 71st Annual Conference and Expo (the "Expo") sponsored by the New York State Health Facilities Association, Inc., and the New York State Center for Assisted Living ("NYSHFA", "NYSCAL") and being held at the Turning Stone Resort & Casino, Verona, NY. Upon execution hereof by a duly authorized representative of the Exhibitor, the Contract shall be binding upon the Exhibitor, NYSHFA / NYSCAL.
- 2. DESCRIPTION OF EXHIBITION SPACE/TIMES:** The area available for exhibition spaces in the exhibit hall will consist of 10' wide x 10' deep pipe and drape with 8' high back wall and two (2) 3' high side rails. In addition, one (1) 6' draped table, two (2) chairs, waste paper basket and a 7" x 44" identification sign will be provided. Exhibit hall hours and dates will be 3:00pm–5:00pm on May 19, 2020 and 11:45am–1:45pm on May 20, 2020.
- 3. RENT:** An exhibition space may be rented for the Expo in accordance with the following rate schedule: NYSHFA / NYSCAL Associate Members -- \$975.00 and Non-Members -- \$1,275.00. Double spaces are permitted for twice the amount of a single space. Payment is due with the return of this Contract; no company will be allowed to set up an exhibition space unless full payment has been received. Make checks payable to NYSHFA or complete the credit card information.
- 4. RESERVATION OF EXHIBITION SPACE:** Reservations for an exhibition space at the Expo may be made by returning a signed contract with the rent payment to NYSHFA. NYSHFA / NYSCAL will accept the reservations in the order in which signed contracts with rental payments are received.
- 5. USE OF EXHIBITION SPACE:** Exhibitor agrees to utilize its exhibition space strictly in accordance with the Rules and Regulations governing Exhibition Spaces which are contained in this brochure and by this reference made a part hereof.
- 6. CANCELLATION POLICY:** For cancellations received by NYSHFA / NYSCAL prior to sixty (60) days before the Expo, a full refund will be made minus a \$100.00 administration charge. There will be no refunds for cancellations made less than sixty (60) days before the Expo.
- 7. FORFEITURE OF EXHIBITION SPACE:** An Exhibition Space not occupied by 3:00 p.m. on the first day of the Expo (May 19, 2020), will be subject to forfeiture by the Exhibitor, and this space may be resold or reassigned by NYSHFA / NYSCAL without refund to the Exhibitor.
- 8. INDEMNIFICATION:** The Exhibitor agrees to indemnify, defend and hold NYSHFA / NYSCAL and its members, officers, agents and employees harmless from and against any and all claims, causes of action, judgments, liabilities, damages, losses, costs and expenses, including reasonable attorneys' fees, arising as a result of Exhibitor's rental and use of an exhibition space, including, but not limited to liability for loss or damage to property and liability for personal injury or death of any person.
- 9. ASSIGNMENT:** The Exhibitor may not assign its rights under this Contract or sublease its exhibition space without the prior written consent of NYSHFA/NYSCAL.
- 10. CHANGE OF THE EXPO DATE:** NYSHFA / NYSCAL reserves the right to change the Expo dates and site upon not less than ninety (90) days prior written notice to Exhibitors. In the event Exhibitor thereafter notifies NYSHFA / NYSCAL in writing that it cannot use the exhibition space on the new date or at the new site, Exhibitor shall be entitled to a full refund of its rental payment.
- 11. CONFERENCE APP:** Exhibitors will have their company logo, company contact information and website listed on the app. Please email your company logo to Erin Fitzgerald (efitzgerald@nyshfa.org) by April 17, 2020.

**IN WITNESS WHEREOF, the Exhibitor has caused this Contract to be signed and dated
by its authorized representative.**

Authorized Signature

Name (Please Print)

Company Name (Please Print)

Date

PAYMENT INFORMATION

Are you an Associate Member of NYSHFA / NYSCAL: YES NO

Company / Organization Name: _____

Contact Person: _____ E-Mail: _____

BOOTH RENTAL: Associate Members: \$975.00 Non-Members: \$1,275.00

BOOTH SPACE: Single Double**

**Billed at twice the listed fee.

METHOD OF PAYMENT <input type="checkbox"/> Check (Make Payable to NYSHFA) <input type="checkbox"/> AMEX <input type="checkbox"/> Discover <input type="checkbox"/> MasterCard <input type="checkbox"/> Visa	Credit Card Number: _____	Exp. Date: _____
	Cardholder Name: _____	
	Billing Address: _____	
MAIL COMPLETED FORM & CHECK TO: NYSHFA / NYSCAL 33 Elk Street, Suite 300 Albany, New York 12207	Authorized Cardholder Signature: _____	

I authorize NYSHFA/NYSCAL/FQC to use the above AMEX, Discover, MasterCard or Visa to charge applicable registration fees.

PLEASE NOTE: PAYMENT WILL SHOW ON YOUR CREDIT CARD STATEMENT AS COMING FROM NYS HEALTH FACILITIES ASSOCIATION.

RETURN CONTRACT & PAYMENT TO:

CONTACT

Erin Fitzgerald
 efitzgerald@nyshfa.org

Scott Jackson
 sjackson@nyshfa.org

COMPANY INFO:

NYSHFA / NYSCAL
 33 Elk Street, Suite 300
 Albany, NY 12207

PH: 518.462.4800
F: 518.462.4370

OTHER MARKETING OPPORTUNITIES

**Information on Sponsorships will be issued separately.
 For further information, please contact:**

ERIN FITZGERALD
 518.462.4800 ext. 22
 efitzgerald@nyshfa.org

SCOTT JACKSON
 518.462.4800 ext. 27
 sjackson@nyshfa.org

2019 EXHIBITOR LISTING

Abbott Point of Care
ACADIA Pharmaceuticals, Inc.
Accelerated Care Plus
Act II Interiors
Aegis Energy Services
American Roofing & Coating Systems
Arrow Exterminating Co., Inc.
Atlantic Tomorrows Office
Avanir Pharmaceuticals, Inc.
Bates Troy Healthcare Linen Services
John W. Baumgarten Architect, P.C.
Cardinal Health
Careone/Healthbridge Management
Castleton Group
CCI Systems
Centers Business Office
Clinical Staffing Resources
Community Care Rx
The Compliance Store
Coretactics Healthcare Consulting
Custom Computer Specialists
Dentserv Dental Services, P.C.
Drapery Industries, Inc.
ElderPlan
EZ Way Inc.
EZaccessMD
Fresh Scents, Inc.
H&R Healthcare
Harmony Healthcare International
Hartmann USA
Health Direct Pharmacy Services
Healthcare Services Group, Inc.
HireFlux, LLC
IPPC Pharmacy
The JonesZylon Company, LLC
Language Fundamentals, Inc.
Law Office of Pullano & Farrow
Linde - Healthcare Division
LiquiTech, Inc.
Logisticare | Circulation
M&T Bank
Marquis Home Care
Masimo
MatrixCare
McKesson Medical - Surgical
Meals for All, Inc.
Medi Lazer
Medical Staffing Network
Medline Industries
Med-Mizer, Inc.
Mindful Caring
Molnlycke
National Health Rehab Physiatry
New York Chapter ACHCA
New York eHealth Collaborative
NRC Health
Nurse Connection Staffing
Omnicare, a CVS Company
ONEGROUP Bailey & Haskell Insurance
Paxxon Healthcare Services
PharMerica
PharmScript
Point Click Care
PORT (RehabCare)
Precision Health, Inc.
Preferred Therapy Solutions, LLC
PRIME Services, Inc.
Procure LTC Pharmacy
Relias
S&T Bank
Securitas
Select Rehabilitation, LLC
Sensible Medical Innovations, Inc.
Shoppers Service, Inc.
Siemens Industry, Inc.
Sightrite
SMD Inc.
Special Care Systems, LLC
Specialty Rx
STARPRO
STAT Portable X-Ray, Inc.
TAG Solutions LLC
Theradynamics Rehab Mgmt., LLC
TotalKare of America, Inc.
Towne Nursing Staff
TypoDuctions
Unidine
United Healthcare / Optum
Woodmark Pharmacy of New York
Wound Healing Solutions
Zimmer Healthcare Services Group, LLC

NYSHFA
NYS HEALTH FACILITIES ASSOCIATION

NYSCAL
NYS CENTER FOR ASSISTED LIVING